



# **DRUM AND DISC MOWERS**

**REAR, FRONT, TRAILED  
DOUBLE-SIDED AND COMBINATIONS**







# Over 35 years of experience



The fodder made of grass is one of the best and at the same time the cheapest nourishment for livestock. By using the proper equipment it is possible to reach the swath, which can be easily processed to very nutritious fodder for cows.

SaMASZ agricultural machines are the guarantee of reaching the most valuable fodder from the mowed area. The solutions used in our machines have been developed by SaMASZ engineers for more than 35 years. For a long time they have been one of the most desired equipment, sought all over the world, because owing to them the fodder will suffice for longer time. It happens, because we have developed the whole technological process of harvest in the slightest detail.

## TABLE OF CONTENTS

## PAGE

Rear 2-drum mowers	4 - 6
LiteCUT cutterbar	8
Samba disc mowers	9
ALPINA front disc mowers	10
SAMBA front disc mowers	11
PerfectCUT cutterbar	12 - 13
KDT disc mowers	14 - 15
KDTC disc mowers	16 - 17
KT disc mowers	18 - 21
XT disc mowers	22 - 23
KDC trailed disc mowers	24 - 25
KDF and TORO front disc mowers	26 - 27
KDD disc mowers	28 - 37





## Rear 2-drum mowers

Z 010, Z 010/1, Z 010/2

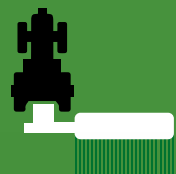

## Economy and precision of mowing...

Drum mowers 1,65 m (5'5") to 2,10 m (6'11") have solid design and are very durable. Tough, resistant gearbox is the most essential part of all our mowers.

Special mowing drums transport cut material and lay it down into a smooth swath.



Z 010



Z 010/1H

Thanks to hydraulic lifting (optional equipment), mower can be easily transported at the rear or side of the tractor.

### Advantages:

- Genius invention of 20th century - cuts perfectly either lying grass or very high sedge - cane,
- Factory set 5,8 cm (2") cutting height, regulated by distance rings,
- DLG Signum Test,
- Solid and tough design,
- Idling running:
  - on PTO shaft (Z 010/2)
  - on pulley (Z 010 and Z 010/1),
- Safety breakaway device,
- Additional knives and mounting lever,
- Ideally fitted to the ground and even working height,
- Safety breakaway device spring with adjustable deflection,
- Quick and easy knife replacement,
- Standard-delivered PTO shaft with holder,
- Low noise and stable operation,
- PTO 540 rpm,
- Adjustable lower pins,
- Solid metal guard with cover,
- Hydraulic lifting system (option).

### Z 010/2

View without safety guards



### Mowing drum section overview

#### Bevel gears

- low-noise and stable operation

#### Blade holder and blades

- straight blade:
- Z 010, Z 010/1 and Z 010/2: 102 mm, made of hardened steel
  - quick blade replacement
  - additional blade holder mounting holes

#### Cutting height adjustment

- with distance rings

#### Vertical drive shaft

- made of high-class steel
- supported in 5 bearing points
- high stability even in most demanding conditions

#### Sliding disc

- strong and durable design - 5 mm / 0.2" thick
- made of wear and abrasion resistant steel

#### 2 double-row ball bearings

- durability and extended life

Typ	Working width [m / ft]	Swath width [m / ft]	Working capacity [ha/h / ac/h]	Number of knives [pcs.]	Power demand [HP]	RPM	Dimensions w / l / h [ft]	Weight [kg / lbs]
Z 010	1,65 / 5'5"	0,70 / 2'4"	~ 1,50 / 3,7	6	from 40	540	11,00 / 5,00 / 3,80	400 / 880
Z 010/1	1,85 / 6'1"	0,80 / 2'7"	~ 2,00 / 5		from 60		12,20 / 5,30 / 3,35	455 / 1005
Z 010/2	2,10 / 6'11"	0,90 / 2'11"	~ 2,50 / 6,2	8	from 70		13,45 / 5,75 / 3,50	555 / 1225





## Front 4-drum mowers

K4BF 265, K4BF 300

Front drum mowers are characterized by perfect ground following, thanks to suspension with support springs. Mower is transported with side covers uplifted. Thanks to this, the transport width is re-

duced significantly, which then provides a problem-free drive. Combination of front and rear mower, allows to obtain working width up to 6 m (20'), which greatly improves work efficiency.



K4BF 265

### Advantages:

- High capacity – even in tough conditions,
- Lifted side safety guard,
- Factory set working height at 5,8 cm (2 1/3") regulated by distance rings (8 mm (1/3")),
- Ideally fitted to the ground and even working height,
- Perfect in combination with disc and drum mowers,
- Limit chains with rubber safety bumpers,
- Set of hydraulic cylinders in standard equipment
- Double support springs,
- Tractor's triangle cat. II in standard equipment,
- Stone tested safety guards (PN-EN ISO 4254-12),
- PTO shaft with overrunning friction clutch in standard equipment,
- Adjustable mowing height,
- Quick and easy knife replacement,
- Solid and tough design,
- Silent and stable operation.

Typ	Working width [m/ft]	Swath width [m/ft]	Working capacity [ha/h / ac/h]	Number of knives [pcs.]	Power demand [HP]	RPM	Dimensions w / l / h [cm]	Weight [kg / lbs]
K4BF 265	2,65 / 8'8"	1,20-1,60 / 3'9"-5'25"	~ 3,00 / 7,50	12	from 80	1000	326 / 138 / 122	780/1720
K4BF 300	3,00 / 9'10"	1,40-1,80 / 4'6"-5'9"	~ 3,50 / 8,70	18	from 90		369 / 144 / 122	860/1895





# Precise CUTTING

Cutterbar

# LiteCUT

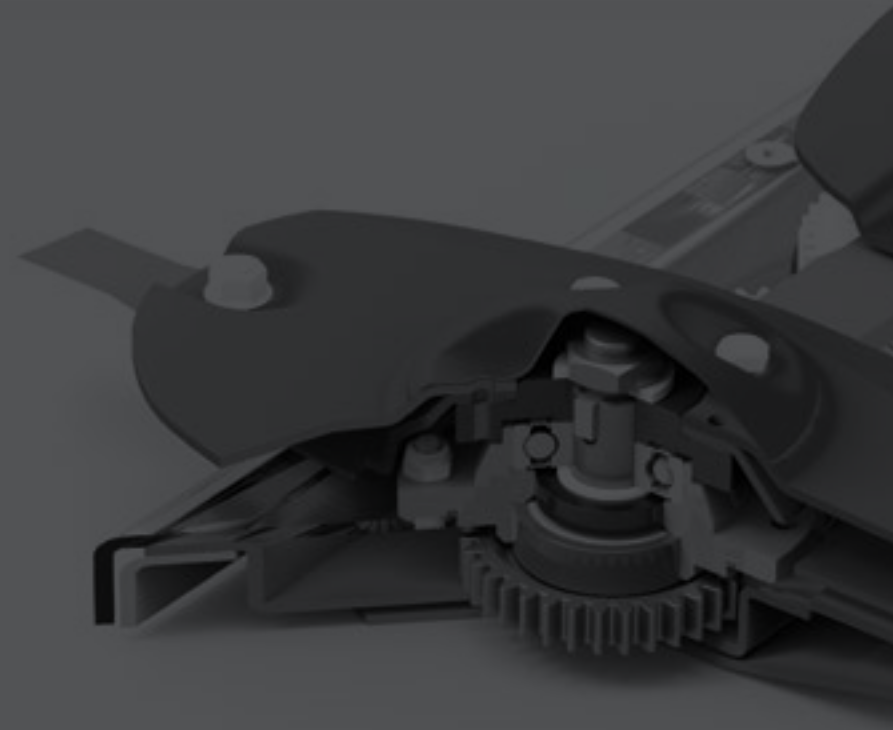

New LiteCUT cutterbar is another model of the cutterbar installed in lightweight mowers - SAMBA. Designed for operation on smaller farms and on hilly and swamp areas. Completely new design provides reliability, high durability and precise cutting line, and all that with reduced power demand.

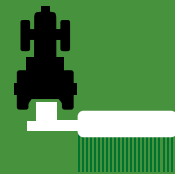

## Disc mowers with LiteCUT cutterbar

Samba 160, Samba 200, Samba 240, Samba 280, Samba 320

LiteCUT

### Design

- lightweight, durable, bolted
- thick, 5 mm / 13/64" steel shell

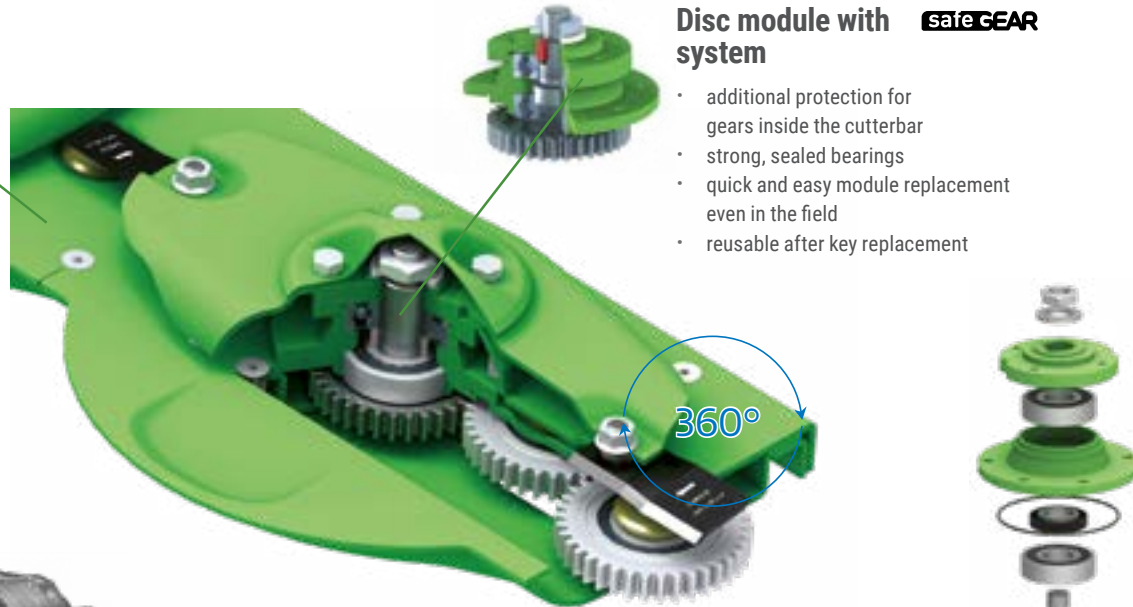

### Hardened gearbox slide

- cutterbar's drive protection



### Central knife holder

- improved shape of the holder enables thorough cleaning of the cutterbar
- made of high quality hardened steel
- 360\* range of rotation
- quick and easy replacement



### Sliding skid

- hardened,
- extend machine's life,
- easy to replace

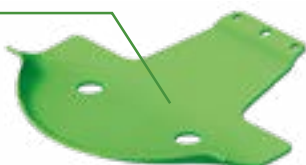

### Disc module with safe GEAR system

- additional protection for gears inside the cutterbar
- strong, sealed bearings
- quick and easy module replacement even in the field
- reusable after key replacement



### safeGEAR protection system

- sheared key safety feature as standard

### Gears - 18 mm thickness

- precisely ground and fitted enable ideal drive transmission and silent work
- protected by safeGEAR system
- set on closed 2RS bearings

### Hardened knives (L=105 mm / 4 9/64")

- SaMASZ logo proves the highest quality,
- quick knife replacement mounting with special lever at the back side and front of the cutterbar



Rear, lightweight disc mower SAMBA with working widths from 1.60 up to 2.80 m (5'2" to 9'2") is designed to operate on smaller farms. Mower works well in hilly as well as swamp areas, where machines and tractors weight is of

great importance. The use of modernized pressure relief system allows for optimal ground pressure adjustment.

### Advantages of Samba mowers:

- light design,
- lower power demand with comparable alternative drum mower,
- new LiteCUT cutterbar,
- regulated rear and front guards significantly facilitate replacement of cutting knives,
- rubber swath guides resistant to windin-up when operating in higher grass (option),
- setting up: the transport, operating or rest positions by means of hydraulic cylinder.



SAMBA mowers equipped with SaMASZ LiteCUT cutterbar features, quick knife replacement system, hardened discs and slides, central knife holder and strengthened load-bearing bushings. In addition, central knife holders design has a great influence on cleaning the cutterbar.

NEW!

	SAMBA 160	SAMBA 200	SAMBA 240	SAMBA 280	SAMBA 320
<b>Working width [m/ft]</b>	1,60 / 5'2"	2,00 / 6'7"	2,40 / 7'11"	2,80 / 9'2"	3,20 / 10'6"
<b>Transport width / height [m/ft]</b>	1,70 / 2,15 // 5'7" / 7'1"	1,70 / 2,50 // 5'7" / 8'2"	1,70 / 2,90 // 5'7" / 9'6"	1,70 / 3,30 // 5'7" / 10'10"	1,70 / 3,66 // 5'7" / 12'
<b>Swath width [m/ft]</b>	0,80 - 1,10 / 2'8" - 3'7"	1,10 - 1,40 / 3'7" - 4'7"	1,10 - 1,80 / 3'7" - 5'11"	1,50 - 2,20 / 4'11" - 7'3"	1,70 - 2,40 / 5'7" - 7'10"
<b>Necessary hydraulic couplers</b>	1 x single acting				
<b>Working capacity [ha/h // ac/h]</b>	~ 1,50 / ~ 3,70	~ 2,00 / ~ 5,00	~ 2,50 / ~ 6,20	~ 3,00 / ~ 7,00	~ 3,50 / ~ 8,70
<b>Number of discs [pcs.] Number of knives [pcs.]</b>	4 / 8	5 / 10	6 / 12	7 / 14	8 / 16
<b>RPM</b>	540				
<b>3-point hitch cat.</b>	I / II		II		
<b>Power demand [HP]</b>	from 20	from 30	from 45	from 60	from 75
<b>Weight [kg / lbs]</b>	410 / 905	445 / 980	490 / 1080	505 / 1115	560 / 1235
<b>PTO shaft</b>	tractor - mower: with poverrunning clutch				





**NEW!**

## Front disc mower ALPINA

ALPINA 300



**NEW!**

## Front disc mower SAMBA

SAMBA 300 F

**LiteCUT**

### Advantages of the Alpina disc mower:

- lightweight and robust design.
- adjustable swath width and mowing height from 4.5 cm to 7 cm and optional extension by up to 3 cm with high mowing skids.
- Perfect ground tracking in three planes and minimal ground pressure guarantee even cutting without damaging the turf.
- convenient transport with foldable side covers.
- ease of use due to the possibility of changing the direction of rotation by returning the gearbox and cooperation of the machine with tractors with left or right PTO rotation.
- quiet operation.
- low operating costs (most maintenance repairs can be carried out in-house).



### Advantages of the Samba disc mower:

- equipment options (with or without swath guides)
- high level of ground following
- use of a hitch triangle for quick and easy coupling and uncoupling of the machine to the tractor
- easy adjustment of the cutterbar load relief system for accurate mowing and protection of the turf
- possibility of installing topping skids
- drive transmission directly onto the cutterbar to eliminate power loss and make efficient use of the entire width of the cutterbar



	ALPINA 220	ALPINA 260	ALPINA 300
<b>Working width [m / ft]</b>	2,20 / 7'3"	2,60 / 8'7"	3,00 / 9'10"
<b>Transport width / height [m / ft]</b>	2,20 / 7'3"	2,60 / 8'7"	3,00 / 9'10"
<b>Swath width [m / ft]</b>	0,80 - 1,00 / 2'7" - 3'3"	1,00 - 1,20 / 2'11" - 3'7"	1,30 - 1,50 / 4'4" - 4'11"
<b>Working capacity [ha/h / ac/h]</b>	~ 2,00 / 5,00	~ 2,50 / 6,20	~ 3,00 / 7,00
<b>Number of discs [pcs.] / Number of knives [pcs.]</b>	5 10	6 12	7 14
<b>RPM</b>	540 (750 and 1000 on demand)		
<b>3-point hitch cat.</b>	I / II		
<b>Power demand [HP]</b>	from 45	from 60	from 75
<b>Weight [kg / lbs]</b>	465 / 1025	505 / 1114	560 / 1220
<b>PTO shaft</b>	tractor - mower: with overrunning clutch built in: with overload clutch		

	SAMBA 300 F
<b>Working width [m / ft]</b>	3,00 / 9'10"
<b>Transport width [m / ft]</b>	~ 1,40 - 1,70 / 4'7" / 5'7"
<b>Swath width [m / ft]</b>	1,30 - 1,50 / 4'4" - 4'11"
<b>Necessary hydraulic couplers</b>	-
<b>Working capacity [ha/h / ac/h]</b>	3,00 / 7,00
<b>Number of discs [pcs.] / Number of knives [pcs.]</b>	7 / 14
<b>RPM</b>	1000
<b>3-point hitch cat.</b>	II
<b>Power demand [HP] [KM]</b>	from 95
<b>Weight [kg / lbs]</b>	550 / 1210
<b>PTO shaft</b>	tractor - mower: with overrunning clutch built in: with overload clutch
<b>Single rubber swath guide [pcs.]</b>	2



# PERFECT OPERATION

## cutterbar PerfectCUT

PerfectCUT cutterbar :  
KDT, KDTC, KT, KDC, TORO, KDF, KDD, KDD-R, and combinations MegCUT and GigaCUT

Basing on the experience of our customers around the world we have introduced to our production the Perfect CUT cutterbar. Precise cut, high durability of components, protection against sudden disc stoppage in case of coming onto an obstacle, quick and easy disc module replacement owing to modernized upper hub are the main advantages of Perfect CUT cutterbars.



**Replaceable inserts**  
• additional cutterbar protection

**Hardened discs**  
• improved shape of the disc increases its thickness and enables perfect material flow  
• high resistance to wear  
• easy replacement

**Topping plates (option)**  
• increases cutting height - 2, 2,5 or 3 cm  
• bolted to the sliding skid  
• easy replacement



**Hardened, slide wearing pads**  
• additional slide protection  
• exchangeable with topping skids  
• easy to mount

**Modernized, hardened slides**  
• reduce work resistance force  
• shape and form enhance lower fodder contamination  
• underside protection of the cutterbar

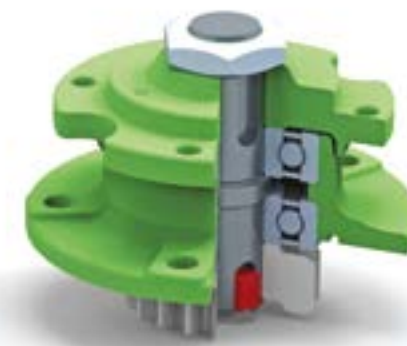

**Disc module with safeGEAR system**  
• additional protection for gears inside the cutterbar  
• strong, double - sealed bearings  
• quick and easy module replacement even in the field  
• reusable after key replacement

**Design**  
• lightweight, durable, bolted  
• thick, 5 mm / 13/64" steel shell

**Hardened discs**  
• improved shape of the disc increases its thickness and enables perfect material flow  
• high resistance to wear  
• easy replacement

360°

**System**  
• protection system  
• sheared key safety feature as standard



**Gears - 18 mm thickness**  
• precisely ground and fitted enable ideal drive transmission and silent work  
• protected by safeGEAR system  
• set on closed 2RS bearings

**Central knife holder**  
• improved shape of the holder enables thorough cleaning of the cutterbar  
• made of high quality hardened steel  
• 360\* range of rotation  
• quick and easy replacement



**Hardened knife holder pins**  
• modernized shape of the pin increases knife stability  
• longer resistance to wear thanks to Geomet® coat  
• separate, replaceable element of the cutting disc



**Hardened knives (L=105 mm / 4 9/64")**  
• SaMASZ logo proves the highest quality,  
• quick knife replacement mounting with special lever at the back side and front of the cutterbar

**Knife mounting lever**  
• quick and easy knife replacement



### Stepless regulation of cutting height (from 3 cm / 1 1/4" to 7 cm / 2 3/4")

- setting the machine to standard cutting height from 4,5 cm / 1 3/4" (from 2° to 0°) enables ideal adjustment of the mower to working conditions (optionally topping skids and double topping skids enable cutting height up to 12 cm / 5")

- proper adjustment of cutting height (min. 6 cm recommended) has a great influence on the quality of cut hay and on the condition, height and the rate of growth of next crops:

- leaving longer stems of 7 cm / 2 3/4" decreases the risk of fodder contamination by other machines (tedder, rake, baler) thanks to longer distance from the ground

- too low cut grass (lower than 5 cm / 2") weakens the crop and decreases the rate of re-growth. Next crops have less volume and have lower nutritional value

$\alpha$  0° - h 6,8 cm  
 $\alpha$  3° - h 5,3 cm  
 $\alpha$  5° - h 4,4 cm







## Rear disc mowers KDT

KDT 220, KDT 260, KDT 300, KDT 340, KDT 341

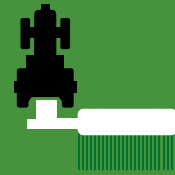

## Precise cut

KDT 220 W, KDT 260 S, KDT 260 W

PerfectCUT

**KDT is the most frequently purchased range from SaMASZ offer. Since the beginning of their introduction to the market, KDT mowers have been used by thousands of customers around the world. Made of best quality materials are a reasonable choice even for the most demanding customers. The machine can be equipped with light-weight conditioner with plastic tines (SL version), which is 25 kg (55 lbs) lighter than the standard one.**

### Mechanical safety breakaway device (with hardened inserts)

In case of hitting an immovable obstacle the breakaway device is pulled out of its housing and the mower folds back giving time to stop working and evade the obstacle. The force, at which, the device will operate is regulated by means of a coil spring. Breakaway device is set by the manufacturer and ensures proper and faultless work.

### Support mechanism when taking turns on headlands.

Owing to this system an operator does not have to pay attention to the height to which he lifts the machine. It also saves times, crucial during forage pick-up.

### Swath guides as standard equipment

Owing to this system an operator does not have to pay attention to the height to which he lifts the machine. It also saves time, crucial during forage pick-up.

### Transport and operation

Lighter and stronger suspension as well as hydraulics facilitate maneuvering and transport.

Switching from working to transport position by means of hydraulic cylinder.

For the time of transport, there are following safety features:

- Mechanical lock
- Hydraulic cylinder shutoff valve



- **V-belts – the drive is transmitted through V-belts, which also function slip as clutch.**
- **New gearbox – 60% stronger and 200% more durable transmits the drive from V-belts to cutterbar.**
- **Replaceable, protective sliding skids, made of hard-wearing steel.**

### Support springs

Enhanced coil springs unload ground pressure and reduce resistance during work.



### Conditioner

Using tine conditioner decreases plant nutrition losses and increases swath density. When mowing caney crops the best effects are reached with roller conditioners.

Detailed description of tine and roller conditioners – page 20-21

	KDT 220	KDT 260	KDT 300	KDT 340	KDT 341*	KDT 220 W**	KDT 260 S**	KDT 260 W**
<b>Working width [m / ft]</b>	2,20 / 7'2"	2,60 / 8'7"	3,00 / 9'10"	3,40 / 11'2"	3,40 / 11'2"	2,20 / 7'2"	2,60 / 8'7"	2,60 / 8'7"
<b>Transport width / height [m / ft]</b>	2,15 / 2,85 7'1" / 9'4"	2,15 / 3,40 7'1" / 11'2"	2,15 / 3,75 7'1" / 12'3"	2,20 / 4,20 7'2" / 13'8"	2,20 / 4,20 7'2" / 13'8"	2,15 / 2,95 7'1" / 9'7"	2,15 / 3,40 7'1" / 11'2"	2,20 / 3,40 7'2" / 11'2"
<b>Swath width [m / ft]</b>	1,00 - 1,40 / 3'4" - 4'7"	1,20 - 1,80 / 3'11" - 5'11"	1,30 - 1,90 / 4'4" - 6'3"	1,40 - 2,00 / 4'7" - 6'7"	2,30 - 2,80 / 7'7" - 9'2"	1,00 - 1,30 / 3'4" - 4'4"	1,00 - 1,30 / 3'4" - 4'4"	1,00 - 1,30 / 3'4" - 4'4"
<b>Necessary hydraulic couplers</b>	1 x single acting							
<b>Working capacity [ha/h / ac/h]</b>	~ 2,50 / 6,20	~ 3,00 / 7,40	~ 3,50 / 8,70	~ 4,00 / 10,00	~ 4,00 / 10,00	~ 2,00 / 5,00	~ 2,80 / 7,00	~ 2,80 / 7,00
<b>Number of discs [pcs.] / Number of knives [pcs.]</b>	5 / 10	6 / 12	7 / 14	8 / 16	8 / 16	5 / 10	6 / 12	6 / 12
<b>RPM</b>	540							
<b>3-point hitch cat.</b>	II							
<b>Power demand [HP]</b>	from 50	from 70	from 80	from 90	from 90	from 70	from 90	from 90
<b>Weight [kg / lbs]</b>	670 / 1480	725 / 1600	785 / 1730	825 / 1820	825 / 1820	950 / 2095	995 / 2195	1005 / 2215
<b>PTO shaft</b>	tractor - mower: with overrunning clutch					tractor - mower: with overrunning clutch built in: with overload clutch		
<b>Single rubber swath guide [pcs.]</b>	2	1	-	-	2	Metal swath guides in conditioner		
<b>Double rubber swath guide [pcs.]</b>	-	1	2	2	-			

\* S - tine conditioner W - roller conditioner

DRUM AND DISC MOWERS 2019/2020





## Rear disc mowers KDTC

KDTC 261, KDTC 301, KDTC 341

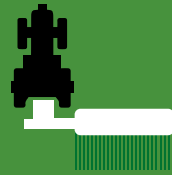

## Exceptional ground following

KDTC 261 S, KDTC 261 W, KDTC 301 S, KDTC 301 W

*PerfectCUT*

**KDTC mowers have been the first disc mowers with central suspension in our offer. They have been manufactured since 2008 and have gone through modernization in order to be up to the present market demands. Developed and thought-through design is an economic alternative to KT mowers. Unlike KT**

**mowers, KDTC mowers have no possibility of applying hydropneumatic suspension. They feature a single transport position (KT has 3 positions). KDTC mower can be equipped with light-weight conditioner with plastic tines, which is 60 kg (135 lbs) lighter than the standard one.**

### PerfectCUT Cutterbar

\*more on p. 12-13

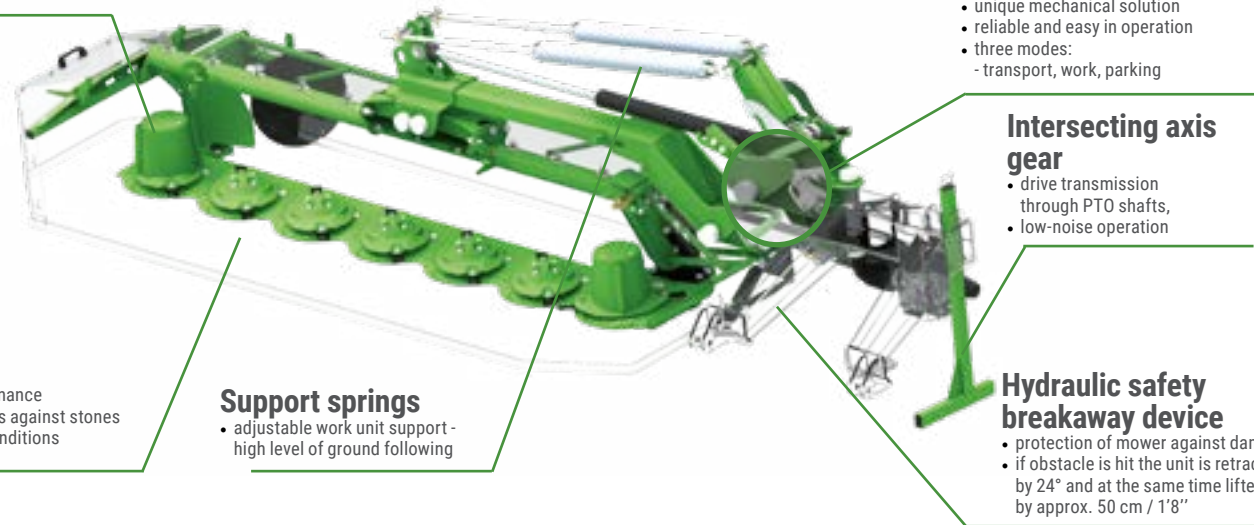

#### Safety guard

- lifted for easier maintenance
- safety curtain - protects against stones
- resistant to weather conditions

#### Support springs

- adjustable work unit support - high level of ground following

#### Patented latch

- unique mechanical solution
- reliable and easy in operation
- three modes:
  - transport, work, parking

#### Intersecting axis gear

- drive transmission through PTO shafts,
- low-noise operation

#### Hydraulic safety breakaway device

- protection of mower against damage
- if obstacle is hit the unit is retracted by 24° and at the same time lifted by approx. 50 cm / 1'8"

### Hydraulic safety breakaway device

KDTC mowers have the same hydraulic safety breakaway device as double-sided mowers. It protects the mower against hitting immovable obstacles. In the event of hitting an immovable obstacle the cutterbar folds back about 30° and at the same time rises about 50 cm (20"). Afterwards, the cutterbar automatically comes back to its working position.



### Positions: transport and rest

Putting the mower into transport and rest positions by means of hydraulic cylinder and patented latch mechanism.



### Advantages of KDTC mowers:

- PerfectCUT cutterbar
- Mechanical latch mechanism, as a support when taking turns on headlands
- Regulated, drop speed of the cutting unit
- Regulated swath guides
- Central suspension enables even ground pressure and perfect ground following
- Wide range of inclination (up to 24 degrees) enables operation on uneven or steep terrain



### Drive

The drive from gearbox to cutterbar's gearbox is transmitted through PTO shaft with friction clutch, which protects the cutterbar against damage.



	KDTC 261	KDTC 301	KDTC 341	KDTC 261 S*	KDTC 261 W*	KDTC 301 S*	KDTC 301 W*
<b>Working width [m / ft]</b>	2,60 / 8'7"	3,00 / 9'10"	3,40 / 11'2"	2,60 / 8'7"	2,60 / 8'7"	3,00 / 9'10"	3,00 / 9'10"
<b>Transport width / height [m / ft]</b>	2,00 / 3,40 6'7"/11'2"	2,00 / 3,80 6'7"/12'8"	2,00 / 4,20 6'7"/13'8"	2,00 / 3,40 6'7"/11'2"	2,00 / 3,40 6'7"/11'2"	2,00 / 3,80 6'7"/12'8"	2,00 / 3,80 6'7"/12'8"
<b>Swath width [m / ft]</b>	1,50 - 1,90 / 4'11" - 6'3"	1,20 - 1,60 / 3'11" - 5'3"	1,20 - 2,00 / 3'11" - 6'7"	1,00 - 1,40 / 3'4" - 4'7"	1,00 - 1,30 / 3'4" - 4'4"	1,40 - 1,70 / 4'7" - 5'7"	1,40 - 1,70 / 4'7" - 5'7"
<b>Necessary hydraulic couplers</b>	1 x single acting						
<b>Working capacity [ha/h / ac/h]</b>	~ 2,80 / ~ 7,00	~ 3,50 / ~ 8,70	~ 4,00 / ~ 10,00	~ 2,80 / ~ 7,00	~ 2,80 / ~ 7,00	~ 3,50 / ~ 8,70	~ 3,50 / ~ 8,70
<b>Number of discs [pcs.] / Number of knives [pcs.]</b>	6 / 12	7 / 14	8 / 16	6 / 12	6 / 12	7 / 14	7 / 14
<b>RPM</b>	540 (1000 - option)			1000			
<b>3-point hitch cat.</b>	II						
<b>Power demand [HP]</b>	from 70	from 80	from 90	from 90	from 90	from 90	from 90
<b>Weight [kg / lbs]</b>	940 / 2075	1020 / 2250	1120 / 2470	1170 / 2580	1215 / 2680	1255 / 2765	1270 / 2800
<b>PTO shaft</b>	tractor - mower: with overrunning clutch + friction, built-in: no clutch						
<b>Single rubber swath guide [pcs.]</b>	1	2	2	Metal swath guides in conditioners			

\* S - tine conditioner W - roller conditioner

DRUM AND DISC MOWERS 2019/2020





## Rear disc mowers KT

KT 261, KT 301, KT 341

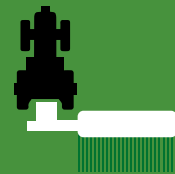

## The same solutions for all models

KT 261 S, KT 261 W, KT 301 S, KT 301 W

*PerfectCUT*

**High operating speed, modern design, quick knife replacement system, central spring or hydropneumatic suspension, 3 transport positions - these are only a few advantages of KT disc mowers!**



### Hydraulic safety breakaway device

Central suspension system is integrated with hydraulic safety breakaway device, which protects the mower against hitting immovable obstacles. In the event of hitting an immovable obstacle the cutterbar folds back and at the same time rises about 50 cm (1'8"). Afterwards, the cutterbar automatically comes back to its working position.



### Central suspension

Main advantages of central suspension are even balance, perfect ground following and wide range of inclination (up to 24 degrees) enabling operation on an uneven grounds and in every conditions. Ground pressure can be relieved by means of springs or hydraulic pressure relief system (hydropneumatic suspension).

### Transport

The most important advantage of KT disc mowers, is possibility to transport the machines in three different positions: A-upwards (at the side of the tractor), B-upwards (behind the tractor) and C-horizontally (behind the tractor). It is possible to drive through narrow roads in the woods or drive under a viaduct or underpass.



### Hydropneumatic suspension

Thanks to hydropneumatic suspension, an operator can easily adjust ground pressure of the cutterbar by means of tractors hydraulics. Owing to that the ground pressure is always the same (no matter how the terrain is shaped). Hydropneumatic suspension is a perfect solution on weak, peat meadows, especially during mowing of the first cut. It allows to adjust required ground pressure - from 70 kg (155 lbs) and provide excellent protection to the turf and the cutterbar.



### Safety guards

- All safety guards and curtains comply with european safety standards.
- Protective tube – increases life span of safety curtain protecting it against wearing by the grass during operation „A”
- Buckles – enable quick and easy safety curtain release „B”
- Guard's regulation – enables lifting and locking in different positions, helpful during quick knife replacement „C”
- Lifted side guard – lower transport high, possibility to work closer to barriers „D”



### Latch mechanism

Innovative, patented latch mechanism enables setting the mower in three different positions, depending on operation mode: operation-rest-transport. Suitable position can be set from tractor's cabin by means of a cord.

### Regulated hitch pins

Headstock is equipped with regulated lower hitch pins (side shift is possible).

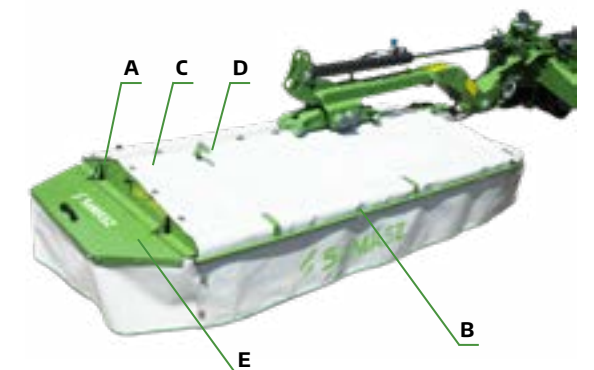

### Manometer

Manometer shows oil pressure in hydraulic system, which reflects actual ground pressure. Setting ground pressure is regulated by means of a lever from tractor's cabin.





## Unique quality of forage

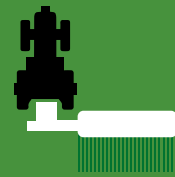

## Tine and roller conditioners

KT 261 S, KT 261 W, KT 301 S, KT 301 W

PerfectCUT

### Advantages of swath conditioners:

- Several times faster grass drying owing to breaking wax layer on a leaf blade
- Cutting wax layer through, facilitates „grass breathing“, which reduces losses in plants nutrition value, and increases swath density
- Elimination of tedding (fewer drives)
- Free presentation of material in wide swath, as well as reducing and balancing its density enables easy pick up for baler or self-collecting trailer
- Increased space between tine shaft and conditioner's hood to improve material throughput at extremely high harvest
- Swath width adjustment by swath guides



### Tine conditioner with new V-claw tine:

- swing mounting allows for the tine to move back when it comes across an obstacle
- increases durability of the bolts owing to limited range of tine's movement
- special shape of the tine prevents the hit against the shaft
- lowers the power demand thanks to better flow of the material

### Integrated gearbox

KT 261 S and KT 301 S mowers have been equipped with integrated gearbox, which apart from the cutterbar also drives the conditioner. Providing two speed rates: 700 and 1000 rpm.

### Tines

Enhanced V-shaped tines are made of hard-wearing steel. Properly balanced tine weight and helical arrangement on the tine shaft provide their effective operation in the heaviest crops. There is a fixed and pivot tine mounting option.

### V-claw tine:

- increased conditioning intensity thanks to tine's angle
- better effect of forage reversing
- long diameter of conditioner's shaft enables easy operation even with high density of material
- ideal aeration of the material with a guarantee of evenly formed swath



### Swath width adjustment in conditioner mowers

Obtaining narrow swath is possible owing to application of additional drums or by swath guides (Fig. 1). Wide swath provides faster and more balanced grass drying process (Fig. 2).

### Advantages of roller conditioners

- Wide rollers along the cutterbar increase efficiency of crushing stems of caney crops
- Rubbing wax from stem's layer and at the same time pressing them out increase drying process
- An inclination of upper roller towards the cutterbar enables better forage pick-up
- Chevron-profiled conditioner rollers interlock to crimp, rub and crush the crop at great intensity
- The rollers are driven by:
  - upper roller – heavy duty bevel belt
  - lower roller – double chain
- Upper roller is suspended on two rockers with clearance regulation by means of springs. It is easy to adapt the roller clearance and pressure to the current crop yield and variety. This solution enables conditioning of large forage crops and their even breaking throughout the whole roller's width. Clearance between the rollers enables stone transport up to 6 cm (2 1/3") diameter

### Replacement of the cutting blades

With the special wrench supplied as standard, the cutting knives can be replaced quickly.



Mechanism that adapts the rollers to the amount of material.

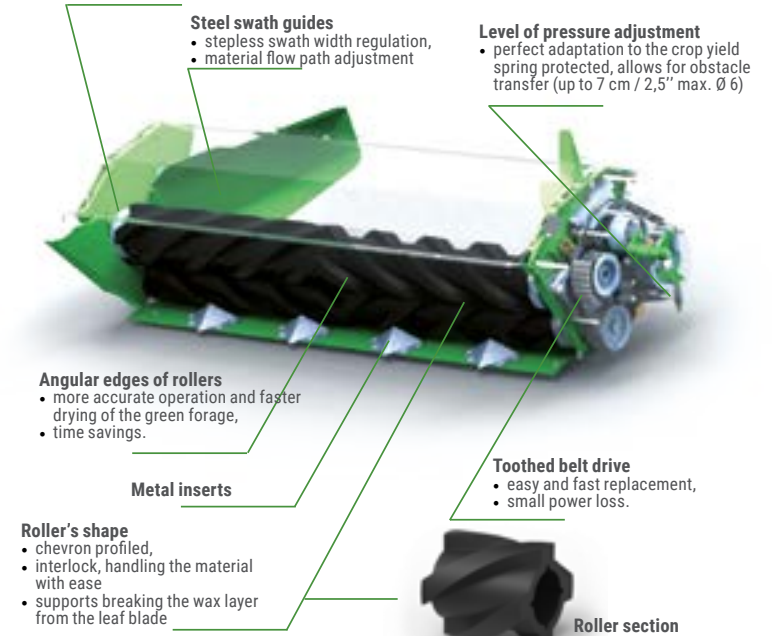

**Steel swath guides**

- stepless swath width regulation,
- material flow path adjustment

**Level of pressure adjustment**

- perfect adaptation to the crop yield
- spring protected, allows for obstacle transfer (up to 7 cm / 2,5" max. Ø 6)

**Angular edges of rollers**

- more accurate operation and faster drying of the green forage,
- time savings.

**Metal inserts**

**Roller's shape**

- chevron profiled,
- interlock, handling the material with ease
- supports breaking the wax layer from the leaf blade

**Toothed belt drive**

- easy and fast replacement,
- small power loss.

Roller section

	KT 261	KT 301	KT 341	KT 261 S*	KT 261 W*	KT 301 S*	KT 301 W*
<b>Working width [m / ft]</b>	2,60 / 8'7"	3,00 / 9'10"	3,40 / 11'2"	2,60 / 8'7"	2,60 / 8'7"	3,00 / 9'10"	3,00 / 9'10"
<b>Transport width / height [m / ft]</b>	2,00 / 3,10 6'7"/10'2"	2,00 / 3,50 6'7"/11'6"	2,00 / 4,20 6'7"/13'8"	2,00 / 3,10 6'7"/10'2"	2,00 / 3,10 6'7"/10'2"	2,00 / 3,50 6'7"/11'6"	2,00 / 3,50 6'7"/11'6"
<b>Swath width [m / ft]</b>	1,50 - 1,90 / 4'11" - 6'4"	1,90 - 2,30 / 6'4" - 7'7"	2,30 - 2,80 / 7'7" - 9'2"	1,50 - 1,90 / 4'11" - 6'4"	1,00 - 1,30 / 3'4" - 4'4"	1,40 - 1,70 / 4'7" - 5'7"	1,40 - 1,70 / 4'7" - 5'7"
<b>Necessary hydraulic couplers</b>	2 x single action + 1 x double action						
<b>Working capacity [ha/h / ac/h]</b>	~ 2,80 / ~ 7,00	~ 3,50 / ~ 8,70	~ 4,00 / ~ 10,00	~ 2,80 / ~ 7,00	~ 2,80 / ~ 7,00	~ 3,50 / ~ 8,70	~ 3,50 / ~ 8,70
<b>Number of discs [pcs.] Number of knives [pcs.]</b>	6 / 12	7 / 14	8 / 16	6 / 12	6 / 12	7 / 14	7 / 14
<b>RPM</b>	540 (1000 - option)			1000			
<b>3-point hitch cat.</b>	II						
<b>Power demand [HP]</b>	from 70	from 80	from 90	from 90	from 90	from 100	from 90
<b>Weight [kg / lbs]</b>	1000 / 2205	1060 / 2335	1130 / 2490	1300 / 2865	1390 / 3065	1350 / 2975	1490 / 3285
<b>Weight with "H" [kg / lbs]</b>	955 / 2105	1015 / 2235	1090 / 2405	1305 / 2877	1360 / 2999	1420 / 3130	1460 / 3220
<b>PTO shaft</b>	tractor - mower: with friction overrunning clutch, built in: no clutch						

\* S - tine conditioner W - roller conditioner

DRUM AND DISC MOWERS 2019/2020





# Rear disc mowers XT

XT 390

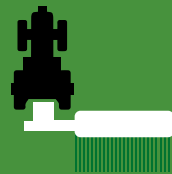

# Precise cut

*PerfectCUT*

The new SaMASZ XT 390 disc mower - you'll cut more, better, and more comfortably! The modern design of the XT 390 completely changes the quality of work and convenience of transport. This

mower, similarly to other SaMASZ models, does not damage the turf, and minimises the level of dirt, so the harvested feed is of the highest purity.

### Safety guard

- lifted for easier maintenance
- safety curtain - protects against stones
- resistant to weather conditions
- lifted side guard decreases transport height

### PerfectCUT Cutterbar

\*more on p. 12-13

### 125° inclined transport position

- decreases transport height to 3,97 m with 3,90 m working width
- increased stability during transport thanks to balanced centre of gravity
- improved visibility in side mirrors

### Unique safety breakaway device:

- hydraulic breakaway device integrated with the hitch and body of the machine
- the inclination of cutterbar on the first disc is higher than 50 cm and is lifted min. 30 cm (the highest range on the market)
- automatic return of the cutterbar to working position

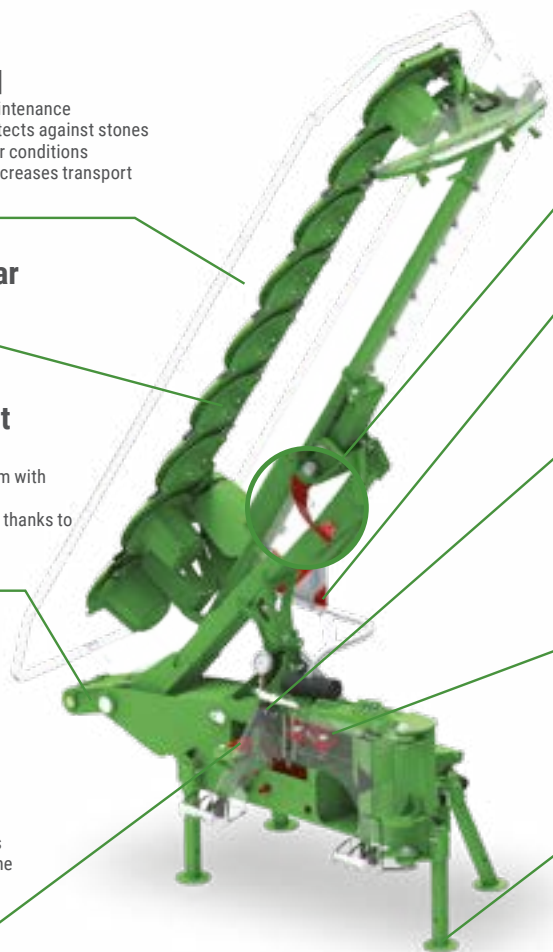

### Machine setting indicator:

- helps to adjust the height of the hitch
- easily visible from tractor's cabin

### Warning plates with LED lights in standard equipment

### KENNFIX hydraulic connector

### Hydropneumatic suspension:

- innovative hydropneumatic lightening system
- integrated with hydraulic safety breakaway device and lifting cylinder
- operated by steering panel directly from tractor's cabin

### Support legs:

- 4 standard support legs enable parking of the machine in transport position
- saves space considerably

### Transport

Another strong point of the XT 390 is its transportability in an inclined position, ensuring safer driving and easier manoeuvrability on both public roads and narrow dirt roads. A great advantage of this machine is its height, which does not exceed 4 m, so, according to the traffic law, it does not require any additional markings or permits. In addition, the XT 390 in the standard version allows the machine to be parked in a stable transport position on four feet.

### Central suspension

The main advantage of central suspension is its even weight distribution, perfect ground following, and large tilting range (up to 24°), which makes it easy to use on uneven terrain, and allows optimum driving in all conditions.

### Hydro-pneumatic suspension

Thanks to its hydro-pneumatic suspension, the operator can use the tractor's hydraulics to quickly adjust the pressure of the cutting bar on the ground, so that, regardless of the terrain, the pressure on the ground is always the same. A large and easily visible pressure gauge informs the operator of the pressure in the hydro-pneumatic system. Another advantage is the possibility to adjust the pressure without leaving the tractor cab, thereby adjusting the load to the conditions.



		XT 390
TECHNICAL DETAILS	Working width [m / ft]	3,90 / 13'
	Transport width / height [m / ft]	2,60/3,98 / 8'7"/13'2"
	Swath width [m]	2,40 - 2,65 / 7'11" - 8'8"
	Necessary hydraulic couplers	1 x double acting
	Working capacity [ha / h]	~ 4,50 / ~11
	Number of discs [pcs.] / Number of knives [pcs.]	9 / 18
	RPM	1000
	3-point hitch cat.	II / III
	Power demand [HP]	from 100
	Weight [kg / lbs]	1 290 / 2 844
	PTO shaft	tractor - mower: with overrunning clutch + friction; built-in: no clutch
	Single rubber swath guide [pcs.]	1





## Trailed disc mowers

KDC 300, KDC 340, KDC 390, KDC 430



## Suitable for any conditions

KDC 300 S, KDC 301 W, KDC 340 S, KDC 341 W

PerfectCUT

**Our design of trailed mowers with central drawbar allows working on both sides of the tractor. It helps to save time when taking turns. KDC mowers can be additionally equipped with tine or roller conditioner and belt conveyor for swath transportation.**

### Tine and roller conditioners

Advantages of tine and roller conditioners are detailed on p. 20-21.

### Driveshaft

Driveshaft inside the drawbar is with no doubt an innovative solution, which has a great effect on extending its life.

### Suspension

Wide frame rocker provides stable cutterbar operation.

### Wide-angle PTO shaft

Wide-angle 960 Nm PTO shaft, if greased every 8 hours, has a warranty for 1000 man-hours!

### Adjustable rigging screws

Regulate angle and working height of the transporter

### Mowing at both sides

Long and center-mounted drawbar is ideal for up and down operation. Changing sides is easy and convenient from the tractor seat. Single-acting cylinders swing the mower over to the other side in up and down operation and swing it centrally behind the tractor in transport position. The center-mounted pivoting drawbar allows mowing up and down the field in either direction.

### Belt conveyor merger

The merger conveys the material onto the existing windrow or next to it to form a double windrow which can be easily picked up by the following harvester. Feeding the crop onto the windrow without the material ever touching ground, the belt conveyor ensures clean forage without losses. Therefore save your time, increase your efficiency, reduce the number of passes and the risk of soil compaction. What is more, it eliminates tedding and raking processes.

### Wide tires

Mower is equipped with wide tires ensuring excellent adhesion and stability. As the machine operates on soft grounds, slopes or water-soaked fields it runs on 340/55-R16 (13.0/55-16) tires that provide light treading to protect the turf. Mounted at a 3° angle, the wheels effectively roll, in direction of travel without pulling to the side.

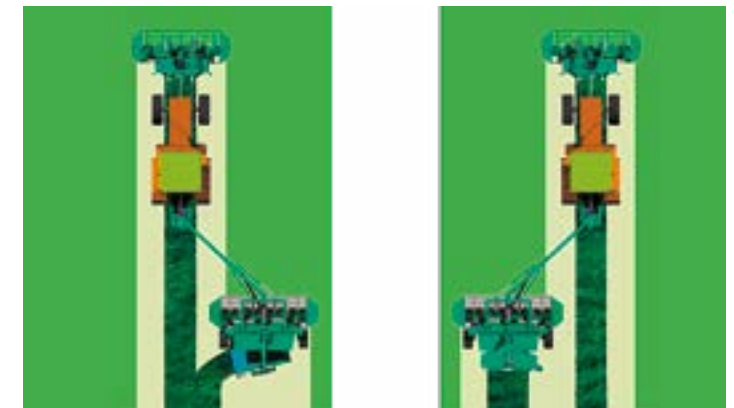

	KDC 300	KDC 340	KDC 390	KDC 430	KDC 300 S	KDC 301 W	KDC 340 S	KDC 341 W
<b>Working width [m / ft]</b>	3,00 / 9'10"	3,40 / 11'2"	3,90 / 13'	4,30 / 14'2"	3,00 / 9'10"			3,40 / 11'2"
<b>Transport width [m / ft]</b>	3,00 / 9'10"	3,50 / 11'6"	3,90 / 13'	4,30 / 14'2"	3,00 / 9'10"			3,40 / 11'2"
<b>Swath width [m / ft]</b>	1,30 - 1,50 / 4'4" - 4'11"	1,70 - 2,10 / 5'7" - 6'10"	2,50 - 3,10 / 8'3" - 10'2"	2,90 - 3,50 / 9'6" - 11'6"	1,00 - 1,60 / 2'11" - 5'3"			1,30 - 2,00 / 4'4" - 6'7"
<b>Necessary hydraulic couplers</b>	1 x single acting 1 x double acting							
<b>Working capacity [ha/h / ac/h]</b>	~ 3,50 / ~ 8,70	~ 4,00 / ~ 10,00	~ 4,50 / 11,30	~ 4,90 / 12,30	~ 3,50 / ~ 8,70			~ 4,00 / ~ 10,00
<b>Number of discs [pcs.]</b> <b>Number of knives [pcs.]</b>	7 / 14	8 / 16	9 / 18	10 / 20	7 / 14			8 / 16
<b>Tires</b>	340 / 55 / 16		400 / 55 / 15		400 / 50 / 15			
<b>RPM</b>	540 / 1000							
<b>3-point hitch cat.</b>	II							
<b>Power demand [HP]</b>	from 80	from 90	from 100	from 110	from 90		from 110	
<b>Weight [kg / lbs]</b>	1650 / 3640	1755 / 3870	1850 / 4080	2040 / 4500	1910 / 4210	2100 / 4630	2095 / 4619	2280 / 5027
<b>PTO shaft</b>	tractor - mower: with friction clutch, built-in: 1. no clutch, 2. with overrunning clutch, 3. with overload clutch, 4. wide-angle u-joint							





## Front disc mowers KDF

KDF 260, KDF 300, KDF 340,  
KDF 301 S, KDF 301 W, KDF 341 S, KDF 341 W / KDF 390



## Economical and efficient

TORO 262, TORO 302, TORO 342

*PerfectCUT*

**KDF front disc mowers could be a perfect alternative for rear mowers due to good visibility during operation and transport. Extended frame and coil springs of long travel enable very good ground following and proper ground pressure. Can be successfully combined, with rear unit, making a very economic set.**

### Advantages and equipment of KDF mowers:

- Mounting triangle as a standard equipment
- PTO shaft with overrunning and friction clutch as a standard equipment
- Mechanical lock for safe transport
- Extended suspension frame and coil springs with long travel enable better ground following (+250 mm, - 150 mm)(+10", - 6") and proper ground pressure adjustment
- Hydraulic cylinders as a standard equipment – facilitate lifting to transport position
- Cutting height indicator as a standard equipment
- PTO safety guard protects the shaft against dirt and fast wear
- Flow divider enables balanced drop and lift of the cutterbar with the use of only one single-acting coupler
- Quick and easy adaptation into clockwise rotation of the front PTO
- Good visibility during operation and transport

### Tine or roller conditioner

Easy to equip with either tine conditioner or rollers. There are also available conditioner tines made of plastic. Particularly important when unit's weight is of great importance. Weight reduction positively affects its working performance on soft and soaked fields.

**The TORO 302 disc mower is designed as a stand-alone mower or as a complement to rear mowers. Thanks to its compact design and spring relief, it is light and energy efficient. The load is relieved by means of precisely selected springs, so that the mower adapts very well to the terrain and protects the turf from damage. TORO 302 is equipped with a double-plane transverse ground tracking system that makes it perfect for selecting transverse irregularities of up to ±10°, as well as for tilting when encountering an obstacle.**

### Advantages and equipment of Toro mowers:

- stepless regulation of cutting height
- use of topping skids possible or double topping skids
- perfect ground following also on uneven and steep terrain
- light design - smaller pressure on the ground
- work with forage collecting machines (self-collecting trailers, balers) possible
- foldable side guards for comfortable transport

### KDF 390 - to Fortshritt

#### Advantages of KDF 390

- PerfectCUT cutterbar
- Quick knife replacement
- High working width
- Light-weight construction
- Smooth regulation of cutting height and swath width
- Swath guides forming up to 2m wide windrow
- Regulated front safety guard
- Lifted side safety guards for transport width reduction
- Very good visibility during work from operator's cabin



KDF 301S



	KDF 260	KDF 300	KDF 340	KDF 301 S	KDF 301 W	KDF 341 S	KDF 341 W	KDF 390 FOR TRACTOR	KDF 390 FORTSCHRITT
<b>Working width [m / ft]</b>	2,60 / 8'7"	3,00 / 9'10"	3,40 / 11'2"	3,00 / 9'10"		3,40 / 11'2"		3,90 / 12'1"	3,90 / 12'1"
<b>Transport width [m / ft]</b>	2,60 / 8'7"	3,00 / 9'10"	3,40 / 11'2"	3,00 / 9'10"		3,40 / 11'2"		3,80 / 12'8"	3,80 / 12'8"
<b>Swath width [m / ft]</b>	~ 01,00 - 1,20 / ~ 3'3" - 3'11"	~ 1,30 - 1,50 / ~ 4'3" - 4'11"	~ 1,40 - 1,80 / 4'7" - 5'11"	~ 1,20 - 2,00 / ~ 3'11" - 6'7"	~ 1,10 - 1,70 / ~ 3'7" - 5'7"	~ 1,40 - 2,40 / ~ 4'7" - 7'11"	~ 1,30 - 2,10 / ~ 4'3" - 6'11"	~ 1,40 - 2,30 / ~ 4'7" - 7'7"	~ 1,40 - 2,30 / ~ 4'7" - 7'7"
<b>Necessary hydraulic couplers</b>	1 x single acting								
<b>Working capacity [ha/h / ac/h]</b>	~ 2,80 / 7,00	~ 3,50 / 8,70	~ 4,00 / 10,00	~ 3,50 / 8,70		~ 4,00 / 10,00		~ 4,50 / 11,00	~ 3,00 / 7,50
<b>Number of discs [pcs.] / Number of knives [pcs.]</b>	6 / 12	7 / 14	8 / 16	7 / 14		8 / 16		9 / 18	9 / 18
<b>RPM</b>	1000								
<b>3-point hitch cat.</b>	II								
<b>Power demand [HP]</b>	from 70	from 80	from 90	from 100		from 110		from 82	
<b>Weight [kg / lbs]</b>	805 / 1775	940 / 2075	1020 / 2250	1260 / 2775	1360 / 3000	1340 / 2955	1475 / 3250	1065 / 2348	820 / 1810

	TORO 262	TORO 302	TORO 342
<b>Working width [m / ft]</b>	2,60 / 8'7"	3,00 / 9'8"	3,40 / 11'2"
<b>Transport width [m / ft]</b>	2,60 / 8'7"	3,00 / 9'8"	3,40 / 11'2"
<b>Swath width [m / ft]</b>	~ 1,00 - 1,20 / 2'11" - 3'7"		
<b>Necessary hydraulic couplers</b>	-		
<b>Working capacity [ha/h // ac/h]</b>	~ 2,80 / 7,00	~ 3,50 / 8,70	~ 4,00 / 10,00
<b>Number of discs [pcs.] / Number of knives [pcs.]</b>	6 / 12	7 / 14	8 / 16
<b>RPM</b>	1000		
<b>3-point hitch cat.</b>	II		
<b>Power demand [HP]</b>	from 60	from 75	from 85
<b>Weight [kg / lbs]</b>	640 / 1410	770 / 1700	850 / 1875
<b>PTO shaft</b>	tractor - mower: with friction clutch built in: with overrunning clutch		





# MegaCUT



**GUINNESS WORLD RECORD**  
**96.2 ha / 237 acres of mowed grass**  
**in 8 hours - MegaCUT 941**

## MegaCUT set

KDD 861, KDD 912, KDD 941



## Combination for demanding farmers

*PerfectCUT*

**MegaCUT is a set of mowers for demanding farmers, who value their time and money. Working efficiency from 10 ha/h and low power demand prove, the combination can be operated even on middle-sized farms with tractor's power starting from 150 HP. It is an excellent alternative to expensive self-propelled mowers.**

**led mowers. MegaCUT set is a perfect solution for large farms. Thanks to their high productivity and working width, cutting of large areas does not take a great deal of time.**

### Central suspension

- work unit located in the center of gravity - even support across the whole cutterbar width,
- perfect ground following enabling work on uneven ground.

### PTO shaft with friction clutch

- Drive from the central gearbox to the cutterbars is transmitted through PTO shafts with overrunning friction clutch, which secure cutterbars from damage.

### Advantages and equipment of MegaCut set:

- PerfectCUT cutterbars with quick knife replacement system
- Protection against stones (quick disc module replacement in case of obstacle collision)
- Central suspension
- Support springs reduce ground pressure and limit mowing disturbances
- Hydropneumatic suspension as an option
- Integrated gearbox (only with conditioner)
- Hydraulic safety breakaway device protects the mower against hitting immovable obstacles. In the event of hitting an immovable obstacle the cutterbar folds back and at the same time rises about 50 cm (20"). The cutterbar automatically comes back to its working position once the obstacle is passed.
- Adjustable swath guides
- Electronic control panel
- Lock mechanism for safe transport transport
- 3-point hitch Cat. II and III

### Own hydraulic unit

- for conveyor drive
- for relieving tractor's hydraulics

### Warning plates with rear road lights (standard)

### PerfectCUT Cutterbar

\*more on p. 12-13

### Safety guard

- lifted for easier maintenance
- safety curtain - protects against stones
- resistant to weather conditions
- lifted side guard decreases transport height

### KENNFIX hydraulic connector

### 4 support legs:

- support legs enable parking of the machine in transport position
- saves space considerably

### Ground pressure relief system

- adjustable work unit support - high level of ground following,
- spring-type as standard,
- hydropneumatic type (option)

### Close-up sensor

- Enables locking the cutterbar at a certain height, when turning on headlands. Operator does not have to control lifting height of the cutterbars and the risk of PTO shaft damage is reduced.

	KDD 861	KDD 912	KDD 941
<b>Working width [m / ft]*</b>	8,60 / 28'2"	9,10 / 29'10"	9,40 / 30'10"
<b>Transport width / height [m / ft]</b>	3,00 / 3,80 // 9'8" / 12'8"	3,00 / 3,90 // 9'8" / 12'10"	3,00 / 4,00 // 9'8" / 13'1"
<b>Swath width [m / ft]</b>	2 x 1,90 - 2,30 / 2 x 6'3" - 7'7"	2 x 1,90 - 2,30 / 2 x 6'3" - 7'7"	2 x 2,30 - 2,70 / 2 x 7'7" - 8'10"
<b>Necessary hydraulic couplers</b>	3 x single acting (steering panel 1 x single acting)		
<b>Working capacity [ha / h // ac/h]*</b>	~ 10,00 / 25,00	~ 10,50 / 27,00	~ 11,00 / 27,00
<b>Number of discs [pcs.]</b>	14 / 28	16 / 32	16 / 32
<b>Number of knives [pcs.]</b>			
<b>RPM</b>	1000		
<b>3-point hitch cat.</b>	III		
<b>Power demand [HP]*</b>	from 130	from 140	from 140
<b>Weight [kg / lbs]</b>	2125 / 4685	2290 / 5050	2290 / 5050
<b>Weight with „H“ [kg]</b>	2100 / 4630	2190 / 4830	2190 / 4830
<b>PTO shaft</b>	tractor - mower: no clutch, built-in: with overrunning friction clutch		

\* Combined with a front mower





# MegaCUT



Lots of possibilities to collect the crop



## Reverse system tractors

KDD-R 861, KDD-R 941, KDD-R 861 S, KDD-R 941 S

PerfectCUT

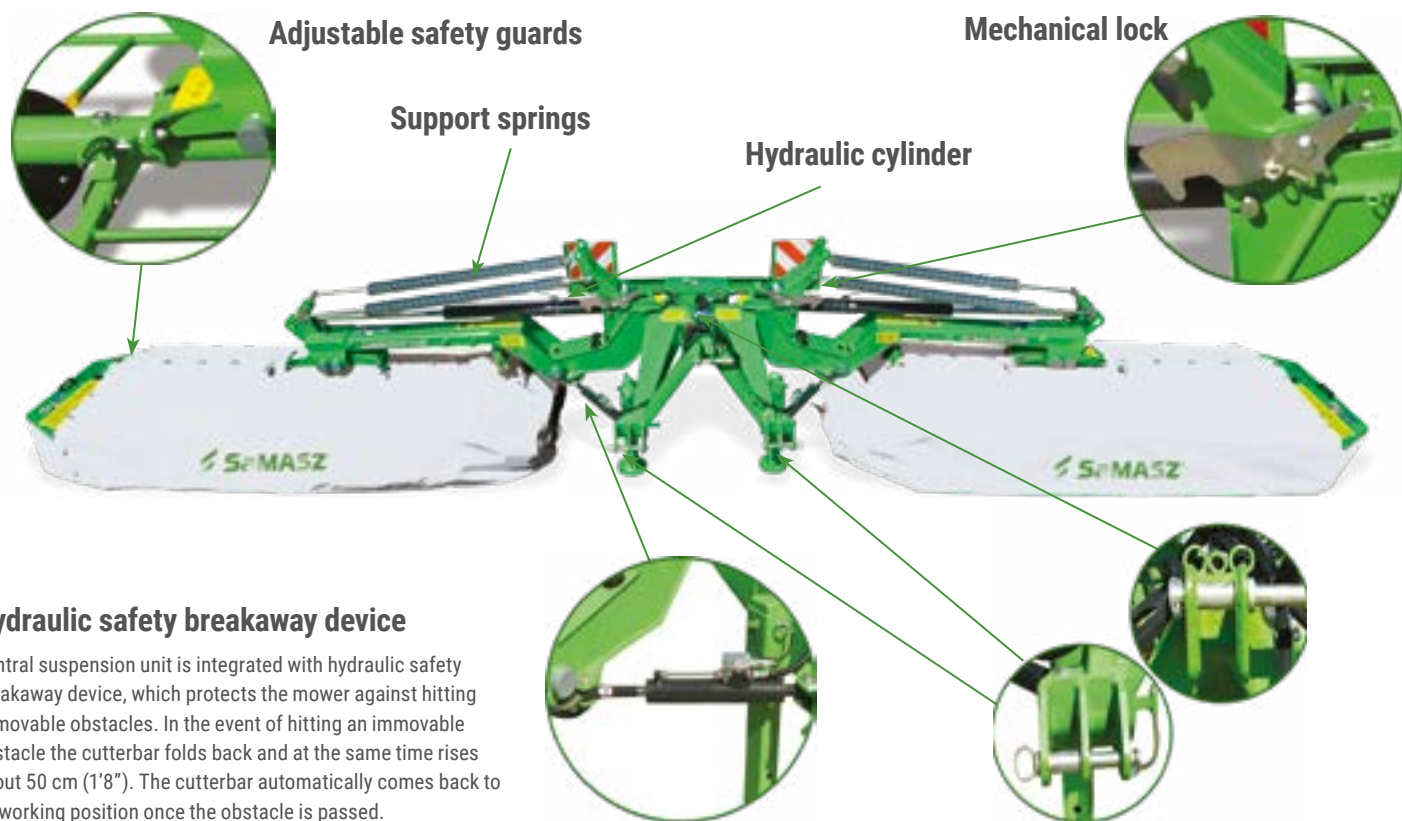

Adjustable safety guards

Support springs

Hydraulic cylinder

Mechanical lock

### Hydraulic safety breakaway device

Central suspension unit is integrated with hydraulic safety breakaway device, which protects the mower against hitting immovable obstacles. In the event of hitting an immovable obstacle the cutterbar folds back and at the same time rises about 50 cm (1'8"). The cutterbar automatically comes back to its working position once the obstacle is passed.

### Electronic control panel

Control panel is installed in operators cabin, which allows convenient control over position of rear mowers on headlands and during transport.



### Transport position

Lowered pivot point allowed for transport height reduction, (less than 4 m / 13'), what ensures safe and comfortable operation on public roads.



In case of using tractor with revers system, KDF front mower can be mounted on KDD-R joint fra-

me. Such solution considerably improves operating comfort and work efficiency of mower set.



### Overlapping of cutting units

Overlapping of front and rear mowers is factory set for 375 mm (1' 2/5"). MegaCUT set always presents three windows.



	MegaCUT-R 861 H	GigaCUT-R 861 SH*	MegaCUT-R 941 H	GigaCUT-R 941 SH*
<b>Working width [m]*</b>	8,60 / 28'2"	8,60 / 28'2"	9,40 / 30'10"	9,40 / 30'10"
<b>Transport width / height [m]</b>	3,00 / 3,80 9'8" / 12'8"	3,00 / 3,80 9'8" / 12'8"	3,00 / 3,95 9'8" / 13'	3,00 / 3,95 9'8" / 13'
<b>Swath width [m]</b>	2 x 1,90 - 2,30 2 x 6'3" - 7'7"	2 x 1,40 - 2,00 2 x 4'7" - 6'7"	2 x 2,30 - 2,70 2 x 7'7" - 8'11"	2 x 1,80 - 2,30 2 x 5'11" - 7'7"
<b>Necessary hydraulic couplers</b>	2 x single acting			
<b>Working capacity [ha / h]*</b>	~ 10,00 / 25,00		~ 11,00 / 27,00	
<b>Number of discs [pcs.]</b> <b>Number of knives [pcs.]</b>	21 (22 with mower KDF 340) / 42-44		23 (24 with mower KDF 340) / 46-48	
<b>RPM</b>	1000			
<b>3-point hitch cat.</b>	III			
<b>Power demand [HP]*</b>	from 150	from 160	from 160	from 180
<b>Weight with 300 [kg / lbs]</b> <b>Weight with 340 [kg / lbs]</b>	3040 / 6700 3120 / 6880	4210 / 9280 4090 / 9015	3130 / 6900 3210 / 7075	4610 / 10165 4490 / 9900
<b>PTO shaft</b>	tractor - mower: no clutch, built-in: with overrunning friction clutch			

\* S - tine conditioner





**GigaCUT**

## GigaCUT set

KDD 861 S, KDD 861 W, KDD 941 S, KDD 941 W



## Huge combination

**PerfectCUT**

**Economy of mowing together with high efficiency is the best description of GigaCUT sets. They have been designed to work on large farms in the toughest conditions possible. GigaCUT combination consists of double-sided mower KDD 861 S/W or 941 S/W and front mower KDF300 S/W or KDF 340 S/W + belt conveyors. Owing to tine or roller conditioner, use of tedder and rake is no longer necessary besides that is a perfect alternative to self-propelled mowers.**

### Safety guard

- lifted for easier maintenance
- safety curtain - protects against stones
- resistant to weather conditions
- lifted side guard decreases transport height

### Ground pressure relief system

- adjustable work unit support - high level of ground following,
- spring-type as standard,
- hydropneumatic type (option)

### KENNFIX hydraulic connector

### 4 support legs:

- support legs enable parking of the machine in transport position
- saves space considerably

### Hydraulic safety breakaway device

- protection of mower against damage
- if obstacle is hit the unit is retracted by 24° and at the same time lifted by approx. 50 cm / 1' 8"

### Warning plates

with rear road lights (standard)

### Belt conveyor

- less drives
- speed adjustment
- no need of tedding and raking

### Central suspension

- work unit located in the center of gravity - even support across the whole cutterbar width,
- perfect ground following enabling work on uneven ground.

### Close-up sensors

- adjustable
- provides easier working on headlands

### Advantages and equipment of GigaCut set :

- PerfectCUT cutterbar with quick knife replacement system
- Protection against stones (quick disc module replacement in case of obstacle collision)
- Central suspension
- 4 support springs reduce ground pressure and limit mowing disturbances
- Hydropneumatic suspension as an option
- Integrated gearbox
- Hydraulic safety breakaway device protects the mower against hitting immovable obstacles. In the event of hitting an immovable obstacle the cutterbar folds back and at the same time rises about 50 cm (20"). The cutterbar automatically comes back to its working position once the obstacle is passed
- Adjustable swath guides
- Electronic control panel
- Latch mechanism for safety during transport
- Own hydraulic and cooling system

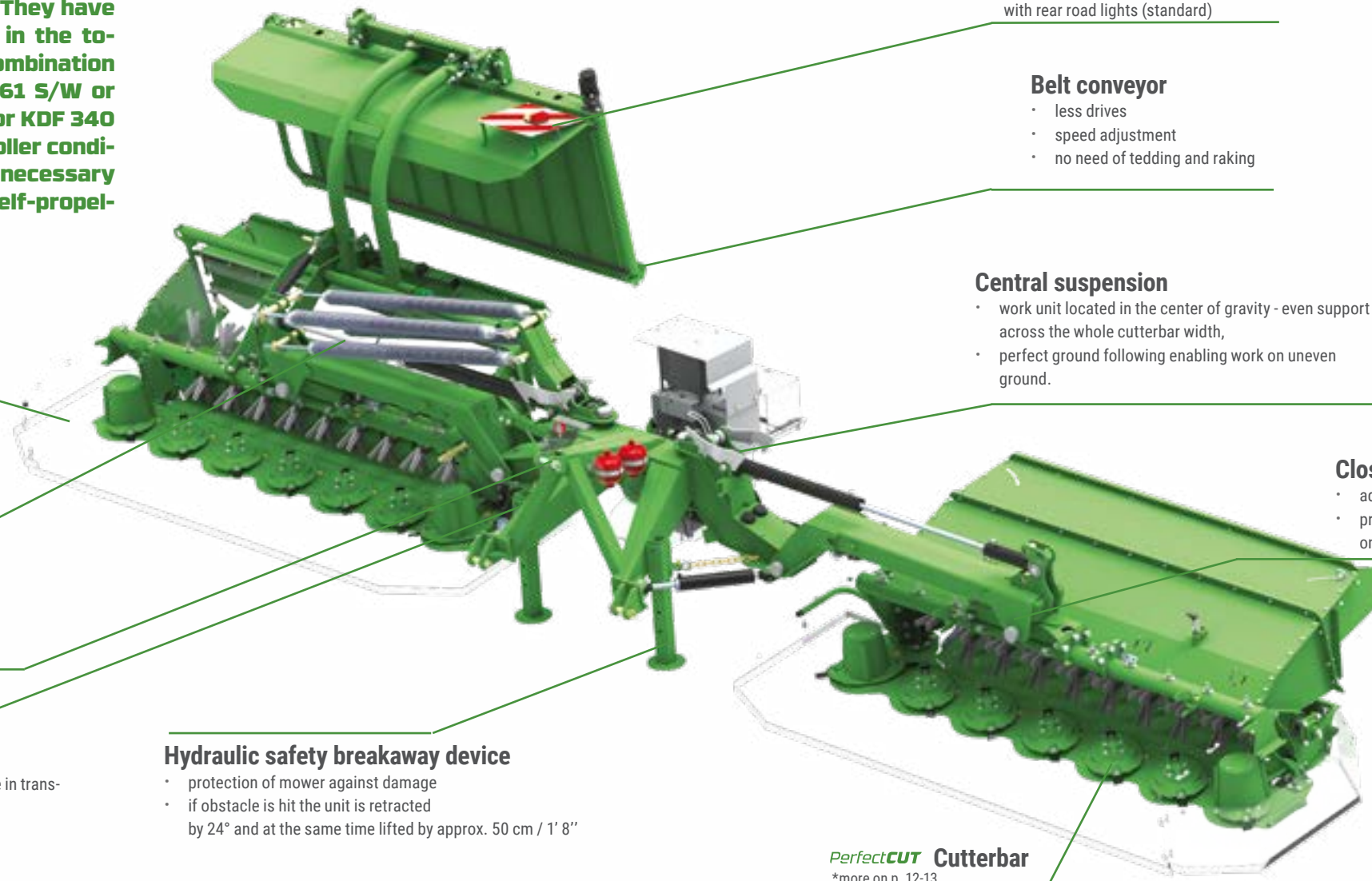

**PerfectCUT Cutterbar**  
\*more on p. 12-13

GigaCUT set can be equipped with tine or roller conditioner. Additionally, belt conveyors can be mounted, owing to which raking is eliminated and therefore the forage harvester needs three times less runs to pick up the crop.





**GigaCUT**



**Lots of possibilities to collect the crop**

KDD 861 S, KDD 861 W, KDD 941 S, KDD 941 W



**High efficiency**

**PerfectCUT**

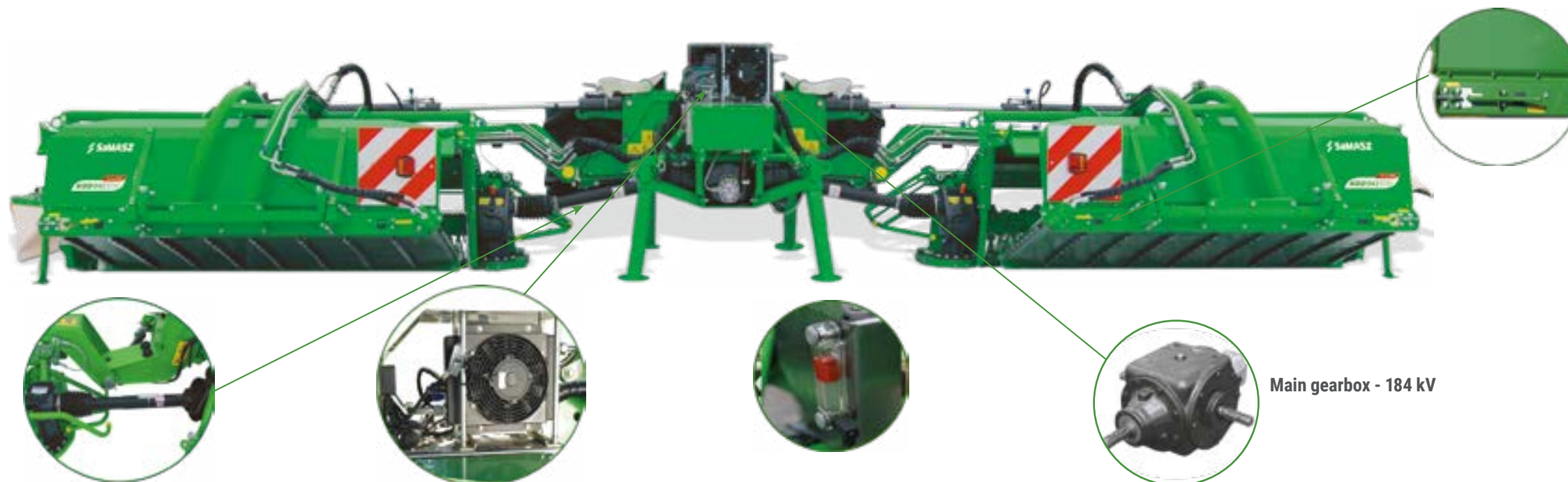

**Belt conveyors drive**

Belt conveyors are driven by their own hydraulic unit (hydraulic pump, radiator and two hydromotors). Turning the conveyors on is done on electronic control panel mounted in tractor's cabin. Mergers work independently with variable speed rates.



**Belt conveyor's cleaning mechanism**

Belt conveyor is equipped with roller cleaning mechanism, owing to which the dirt can be easily removed without necessity to take off the belt. In order to reduce dirt gathering and protect the belt a new type of cleaning brushes was applied.

**PTO shaft with friction clutch**

Drive from the central gearbox to the cutterbars is transmitted through PTO shafts with overrunning friction clutch, which secure cutterbars from damage.

**Hydraulic unit**

The mower has its own hydraulic unit : oil pump, oil container, radiator with a fan and regulated end valve for belt conveyors speed adjustment.

**Oil level and temperature indicator**

Integrated level and temperature indicator placed on oil tank.

**Main gearbox - 184 kV**

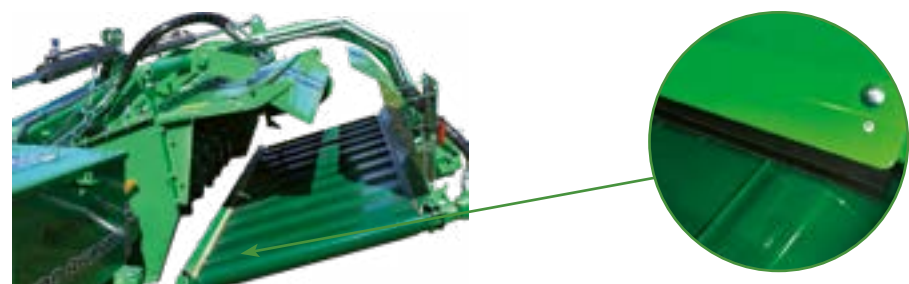

**Belt conveyor**

Strong beams suspend the belt conveyor for ultimate stability when operating in heavy crops, uneven fields and on the slope. They swing the unit up and out of the way when the mower is producing single or wide windrows. Single-acting cylinder raises the belt conveyor as a reversing valve shuts it off and back on when the unit goes down, back into work.



**Electronic control panel**

Control panel is installed in operator's cabin, which allows for convenient control over position of rear mowers on headlands and during transport. It allows for belt conveyor speed adjustment.





# GigaCUT



## The art of cutting



## PerfectCUT



### Manufacturer's advice

Belt conveyor speed can be adjusted via electronic control panel (see p. 30) Ranging from 0 ÷ max. Maximum windrow width of 2,8 m (9' 1/5") may be reached when cutting low and medium grass. When cutting heavy grass, conveyor speed has to be increased due to the weight of the material. This automatically narrows windrow presentation. There is a possibility to move the conveyors

left or right along the mowers frame +/- 200 mm (7 3/4"). However, an operation with the conveyors moved to an extreme point may cause unbalancing of the set. In that case of having 3,5 m (11 2/5") wide swath SaMASZ can manufacture shorter conveyors.

### Transport width

In this position permitted transport width of 3 m is not exceeded.

### Adjustment of cutting units

Overlapping of front and rear mowers is factory set for 375 mm (14 3/5"). MegaCUT set always presents three windrows.



	KDD 861 S	KDD 861 W	KDD 941 S	KDD 941 W
<b>Working width [m / ft]</b>	8,60 / 28'2"	8,60 / 28'2"	9,40 / 30'10"	9,40 / 30'10"
<b>Transport width / height [m / ft]</b>	3,00 / 3,80 9'8" / 12'8"	3,00 / 3,80 9'8" / 12'8"	3,00 / 3,95 9'8" / 13'	3,00 / 3,95 9'8" / 13'
<b>Swath width [m / ft]</b>	2 x 1,90 - 2,30 2 x 6'3" - 7'7"	2 x 1,40 - 2,00 2 x 4'7" - 6'7"	2 x 2,30 - 2,70 2 x 7'7" - 8'11"	2 x 1,80 - 2,30 2 x 5'11" - 7'7"
<b>Necessary hydraulic couplers</b>	3 x single acting (with panel 1 x single acting)			
<b>Working capacity [ha/h / ac/h]</b>	~ 10,00 / 25,00		~ 11,00 / 27,00	
<b>Number of discs [pcs.] Number of knives [pcs.]</b>	14 / 28		16 / 32	
<b>RPM</b>	1000			
<b>3-point hitch cat.</b>	III			
<b>Power demand [HP]</b>	from 160	from 160	from 180	from 180
<b>Weight [kg / lbs]</b>	2920 / 6440	3080 / 6790	3120 / 6880	3010 / 6635
<b>Weight with „H“ [kg]</b>	2785 / 6140	2940 / 6480	3020 / 6660	2875 / 6340
<b>PTO shaft</b>	tractor - mower: no clutch, built-in: with overrunning friction clutch			

	KDD 861 ST	KDD 861 WT	KDD 941 ST	KDD 941 WT
<b>Working width [m / ft]**</b>	8,60 / 28'2"	8,60 / 28'2"	9,40 / 30'10"	9,40 / 30'10"
<b>Transport width / height [m / ft]</b>	3,00 / 3,80 // 9'8" / 12'8"	3,00 / 3,80 // 9'8" / 12'8"	3,00 / 3,95 // 9'8" / 13'	3,00 / 3,95 // 9'8" / 13'
<b>Swath width [m / ft]</b>	2 x 1,90 - 2,30 / 2 x 6'3" - 7'7"	2 x 1,40 - 2,00 / 2 x 4'7" - 6'7"	2 x 2,30 - 2,70 / 2 x 7'7" - 8'11"	2 x 1,80 - 2,30 / 2 x 5'11" - 7'7"
<b>Necessary hydraulic couplers</b>	3 x single acting (with panel 1 x single acting)			
<b>Working capacity [ha/h / ac/h]**</b>	~ 10,00 / 25,00		~ 11,00 / 27,00	
<b>Number of discs [pcs.] Number of knives [pcs.]</b>	14 / 28		16 / 32	
<b>RPM</b>	1000			
<b>3-point hitch cat.</b>	III			
<b>Power demand [HP]</b>	from 160	from 160	from 180	from 180
<b>Weight [kg / lbs]</b>	3791 / 8360	3951 / 8710	4057 / 8945	3947 / 8700
<b>Weight with „H“ [kg / lbs]</b>	3656 / 8060	3811 / 8400	3957 / 8725	3812 / 8405
<b>PTO shaft</b>	tractor - mower: no clutch, built-in: with overrunning friction clutch			

S - tine conditioner W - roller conditioner

S - tine conditioner W - roller conditioner T - transporter



## Selected SaMASZ machines

### Electrophoretic cathode metal coating (E-COAT) - the way for a long surface life

Cataphoretic painting is used to coat elements that require coatings with significant corrosion resistance. Painting workpieces of SaMASZ machines is carried out on a fully automated line with a total length of 900 m. Each stage of the process is constantly monitored and recorded, which ensures the repeatability of the process as well as the highest quality of the coatings obtained.

The technology is always individually tailored to the characteristics of the workpiece and meets restrictive standards. Zinc phosphate surface preparation and KTL painting allow even the most complicated shapes with hard to reach workpiece slots to be covered. Such a coating guarantees the highest anti-corrosion resistance, which is more than 3 times higher than in the case of the standard iron phosphating.

This is extremely important, as it allows for a perfect surface finish. A well-equipped laboratory helps to monitor process parameters and coating quality, which translates into high resistance to weather conditions, corrosion, chemical and mechanical protection and aesthetic appearance.



#### Advantages:

- high quality of the coating,
- covering complex shapes,
- precise control of the coating thickness,
- corrosion protection,
- chemical protection,
- mechanical protection.

extension arms



drum mowers



flail mowers



disc mowers



snow plows



rotary rakes and tedders



tractor gritters and sweepers







**SaMASZ Sp. z o.o.**

**16-060 Zabłudów  
ul. Trawiasta 1  
Poland**

*tel.: + 48 85 664 70 31*

*fax: + 48 85 664 70 41*

*e - mail: [export@samasz.pl](mailto:export@samasz.pl)*

**[www.samasz.com](http://www.samasz.com)**

**True passion and constant seeking of the best solutions are amongst the ideas, which have been essential for the SaMASZ employees and have become the key to the company's success.**

What contributes the most to constant and dynamic development of the company are close contact with our customers and staying open to their needs. Thanks to dialogue with our present and future clients and trying to meet their expectations we create and strengthen up the basis of our dynamic success. We are creating the brand, which is already well recognized not only in the whole Europe, but also in the world.

Considering constant development as our top priority, we invest in product research. Our employees are the most talented Technical University graduates, who are not only experts in their own fields, but also bring in a great dose of professionalism and passion to their duties. You can always count on their competence and reliability.

Your dealer:

Today, SaMASZ is the top Polish and one of the major European manufacturers of forage machinery. Our offer includes more than 300 types of different machines: drum mowers, disc mowers, tedders, rakes, flail mowers, extension arms or snow plows. Since the beginning we managed to manufacture and sell more than 110 000 mowers and few thousands of other machines. We export to more than 50 countries around the world. Our sales network includes approx. 60 companies in Poland and approx. 70 abroad.

Our main goal, which is constant development and implementation to our production cutting edge technology in order to keep the world's top quality. We are fully aware, that in this ever changing reality, customers tend to seek trading partners who are trustworthy, and therefore we have an ambition of being considered as a reliable and professional manufacturer.

