

**C-SERIES MINI EXCAVATORS
CX57C | CX60C**

CASE
CONSTRUCTION



**COMFORT
IN MOTION**

www.casece.com
EXPERTS FOR THE REAL WORLD
SINCE 1842

MAIN REASONS TO CHOOSE THE C-SERIES



OUTSTANDING PRODUCTIVITY

- Flow summation
- Excellent engine power and torque
- Superior lifting capacity



GREAT RELIABILITY

- Hydraulic hoses well protected inside the X-frame undercarriage
- Low risk of detacking with double-flange rollers
- 3-piece track guide as standard
- Full track guide as optional



HIGH VERSATILITY

- Integrated attachments' offering
- Mono or bi-directional hydraulic oil flow
- Additional counterweights available
- Several track options available



OPTIMIZED TRACTION AND SPEED

- Auto shift-down feature
- Efficient travel motors
- Triple-grouser steel tracks with 5 double-flanged rollers



EXCELLENT WORKING RANGE

- Long and short dipper sticks available
- Ample boom swing angles





COMFORT COUNTS

- Low noise inside the cab
- 1° and 2° auxiliary hydraulics control on joysticks
- Touch screen multicolour cluster
- Radio with USB
- Full suspension heated seat
- Automatic Air Conditioning



PRO COVER PROTECTION PLAN 3 YEARS / 3,000 HOURS

ProCover is designed to help keep your equipment working well beyond the manufacturer's base warranty period while taking away the concerns of the cost and inconvenience of mechanical failure.



SAFETY FIRST

- ROPS / FOPS / TOPS certified cab
- Pilot circuit with accumulator
- Object Handling Kit
- Blade safety valves



HIGH EFFICIENCY

- Auto-idle function
- Two working modes
- High Pressure Common Rail technology



EASY SERVICEABILITY

- Easy access to battery, hydraulic valves and all regular service components
- Centralized greasing points
- Pressure check points on hydraulic valves
- Long life of regular maintenance components
- Forward tilting cab (CX60C only)

THE PRODUCTIVITY WITHOUT CONSTRAINTS



HIGH EFFICIENCY

Clean and powerful engine

- Powerful electronic Tier 4 Final / Stage IIIB engine.
- Low fuel consumption with standard auto-idle system and 2 working modes.
- High Pressure Common Rail technology for optimal fuel usage.



HIGH VERSATILITY

Tailor made machines for your specific needs

- Short radius or conventional tail swing (CX60C and CX57C).
- Long and short arms available for maximum digging depth or maximum breakout force.
- Additional counterweights for increased stability and lifting capacity.

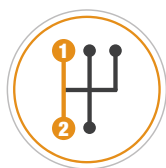

OPTIMIZED TRACTION AND SPEED

Auto Shift-Down feature

The standard Auto Shift-Down feature enhances travel torque and secures travel speed by automatically changing from 2° to 1° gear when additional traction is required, and then back from 1° to 2° gear as soon as torque demand decreases.

C-SERIES MINI EXCAVATORS



MODERN AND FUNCTIONAL CLUSTER

Easy-to-read digital cluster

Everything under Control: Advanced 5.7" color LCD - Touch screen - 12 languages - Engine coolant temperature - Hydraulic oil temperature - Fuel tank level - Complete maintenance information



PEACE OF MIND

ESL Anti-theft

ESL Anti-theft is an Engine Start Limitation (ESL) requiring a 5-digit code can be set by the Operator.



READY FOR TECHNOLOGY

Convenient hands-free feature

- Standard hands-free feature: control mobile phone and radio via Bluetooth.
- MP3 compatible Radio with USB plug and AUX plug for headphones.



READY FOR HOT AND COLD WHEATHER

Automatic climate control

Standard automatic climate control grants a pleasant temperature inside the cab and heated seat.



RADIO AND USB

AUTOMATIC A/C

SUNSHADES

STORAGE COMPARTMENTS

STRESS-FREE WORKING ENVIRONMENT



COMFORT COUNTS

Higher class roominess

- Excellent interior space and cab accessibility make operators daily job more pleasant and relaxed.
- The seat features a weight suspension system, it is heated and fully adjustable.



LOW NOISE AND VIBRATIONS LEVEL

Designed for top Operator's satisfaction

Cab mounted on silent blocks combined with proper noise isolation result in a very quite work environment for C-Series Operators.



HIGH VISIBILITY

Fully glazed cab

- Slim and robust cab pillars allow the usage of large glazed areas that provide outstanding all round visibility.
- Rear view camera as well as rear working lights are available to further enhance visibility.



BOTTLE HOLDER

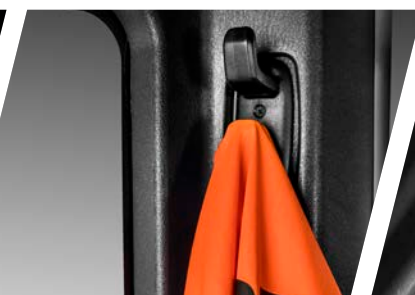

HOOK



PLUGS, 12V OUTLET, SWITCHES



SWITCHES

CONTROL PANEL

C-SERIES MINI EXCAVATORS

STRESS-FREE MAINTENANCE



SAFETY FIRST

No compromise on safety

- **ROPS / TOPS / FOPS:** all C-Series models and versions comply with Roll-Over / Tip-Over and Falling Objects -Protective-Structure requirements.
- **Emergency stop switch:** CX57C and CX60C have as a standard feature a switch that immediately stops the engine in case of an emergency.
- **Pilot system with accumulator:** this standard feature allows the operator to put the attachment down safely even with engine turned off for greater safety.
- **Travel alarm:** an acoustic alarm alerts the people near the machine when it moves forward or backward. This feature is optional on both CX57C and CX60C.
- **Blade safety valves:** prevent the load from slipping or dropping due to hose failure (optional on CX57C and CX60C).
- **Double-flange rollers:** de-tracking can be dangerous for the operator and the people near the machine. CASE C-Series minis have a double-flange roller design that minimizes the risk of de-tracking.
- **Short Radius (SR):** the Short Radius design (on CX60C) means very low risk of hitting obstacles with the rear of the machine when swinging, and creates less obstruction to road traffic.
- **Object handling kit (optional):** includes safety valves on boom and arm, lifting hook on bucket linkage, and an overload alarm to handle heavy weights safely.



EASY AND SAFE SERVICEABILITY

If it's easy it gets done

- Convenient access to all regular service points thanks to a large engine hood.
- Long life of regular maintenance components.
- Forward tilting cab (CX60C only).
- Convenient pressure check points on valves.
- Centralized greasing points and easy to change air filter.



PRO COVER PROTECTION PLAN 12 MONTHS / UNLIMITED HOURS

When the unexpected occurs, you need to know your equipment is protected.

We understand the importance of your machinery being in good working order and additionally to the STANDARD PROTECTION PLAN we offer you to purchase supplementary years/hours to meet your needs.

PROCOVER⁺
Protection Plan



CASE[®]
CONSTRUCTION

SiteWatch[™]

All models are Site Watch telematics pre-wired.

C-SERIES MINI EXCAVATORS

SPECIFICATIONS

	CX57C	CX60C
ENGINE		
Model	Yanmar	Yanmar
	4TNV98C	4TNV98C
Displacement (cm ³)	3319	3319
Rated gross horse power (hp/kW) (ISO 14396)	66.9 / 49.9	64.7 / 48.3
@rpm	2400	2200
Max torque (Nm/rpm)	235 / 1550	235 / 1560
Emissions level	T4F I Stage IIIB	T4F I Stage IIIB
HYDRAULIC SYSTEM*		
Variable displacement axial piston pumps	2 x 18.8	2 x 27.6
Pump delivery (l/min)	2 x 57.8	2 x 55
Pressure (bar)	220	220
Gear pump delivery		
Pump delivery (l/min)	38.4	36.6
Pressure (bar)	220	220
Hammer Circuit 1 - way		
Pump delivery (l/min)	57.8	55
Pressure (bar)	220	220

* Specifications are representative of pump capacity only, not actual hydraulic flow at auxiliary fittings.

SLEWING & TRAVEL SPEED		
Slewing speed (rpm)	9.1	8.8
Boom slewing angle (left/right)	80° / 50°	70° / 50°
Travel Speed - Low (1st) (km/h)	2.1	2.0
Travel Speed - High (2nd) (km/h)	4.1	3.9
OPERATING WEIGHT		
(includes operator, full fuel tank, steel track 380 mm and one bucket)		
Cab (kg)	5580	5980
TRANSPORT FEATURE		
(weight is with full fuel tank, without operator, without bucket)		
Weight (Cab) (t)	5410	5850
A Max length (mm)	5900 5930*	5600 5625*
B Max Height (mm)	2550	2550
N Max Width (mm)	1920	1980

* Long arm

GENERAL DIMENSIONS

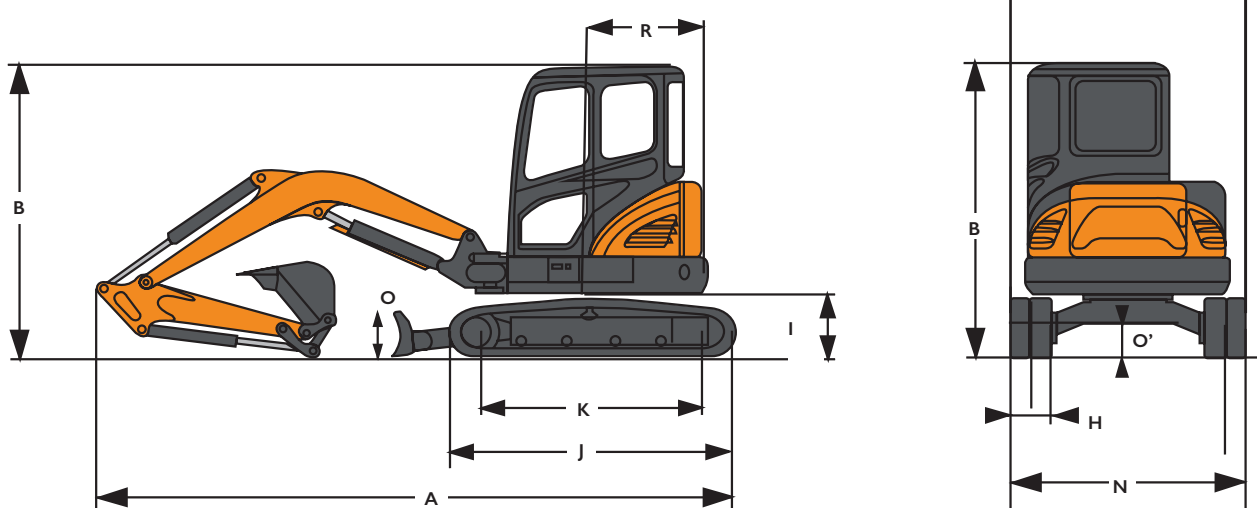

		CX57C	CX60C
R Rear end swing radius	mm	1650	1080
R' Min front slew radius	mm	2350-2360	2420-2510
H Track width	mm	380	380
I ground clearance of rear end	mm	690	660
J Overall Length of Crawler	mm	2530	2530
K Center distance of tumbler	mm	1990	1990
L Blade max lifting	mm	390	200
M Blade max lowering	mm	590	700
N Blade width	mm	1920	1980
O Blade height	mm	350	350
O' Ground clearance of undercarriage	mm	380	380

SPECIFICATIONS

DIGGING PERFORMANCES

	mm	CX57C		CX60C	
		1600	1900		
Dipperstick	mm	1600	1900		
Dipperstick breakout force (ISO)	kN	31.9	28.7	26.5	22.4
Bucket breakout force (ISO)	kN	42.4	42.4	40.9	40.9
D Max reach	mm	6150	6400	6150	6480
D' Max reach at ground level	mm	6010	6270	6010	6350
E Max digging depth	mm	3820	4060	3570	3990
F Max dump height	mm	4050	4180	3930	4100
G Max digging height	mm	5780	5920	5680	5850

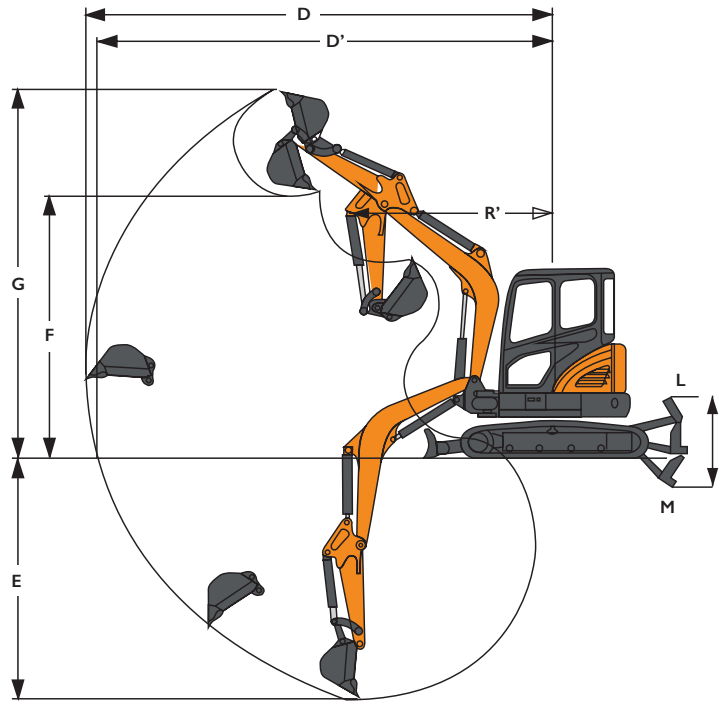

LIFTING CAPACITIES

Lift point height (m)	Arm	LIFT-POINT RADIUS					
		2.0 m		3.0 m		4.0 m	

CX57C Cab - Long arm, no bucket, std counterweight, rubber track (400 mm)

Lift point height (m)	kg	LIFT-POINT RADIUS					
		2.0 m		3.0 m		4.0 m	
1.0 m	Blade up			1650	1290	1070	850
	Blade down			2450*	1430	1700*	940
0.0 m	Blade up	1500*	1500*	1570	1210	1030	810
	Blade down	1500*	1500*	2830*	1350	1900*	900
-1.0 m	Blade up	2740*	2260	1550	1190	1010	790
	Blade down	2740*	2570	2840*	1330	1940*	880

Lift point height (m)	Arm	LIFT-POINT RADIUS					
		2.0 m		3.0 m		4.0 m	

CX60C Cab - Long arm, no bucket, std counterweight, rubber track (400 mm)

Lift point height (m)	kg	LIFT-POINT RADIUS					
		2.0 m		3.0 m		4.0 m	
1.0 m	Blade up			1410	1170	900	760
	Blade down			2640*	1300	1770*	850
0.0 m	Blade up	1360*	1360*	1320	1090	860	720
	Blade down	1360*	1360*	3050*	1220	1990*	800
-1.0 m	Blade up	2470*	2110	1300	1070	840	700
	Blade down	2470*	2410	3020*	1200	2010*	780

CX57C Cab - Long arm, no bucket, additional counterweight (+100 kg), rubber track (400 mm)

Lift point height (m)	kg	LIFT-POINT RADIUS					
		2.0 m		3.0 m		4.0 m	
1.0 m	Blade up			1750	1360	1130	910
	Blade down			2450*	1510	1700*	1000
0.0 m	Blade up	1500*	1500*	1660	1290	1090	870
	Blade down	1500*	1500*	2830*	1430	1900*	960
-1.0 m	Blade up	2740*	2400	1640	1260	1070	850
	Blade down	2740*	2720	2840*	1410	1940*	940

CX60C Cab - Long arm, no bucket, additional counterweight (+200 kg), rubber track (400 mm)

Lift point height (m)	kg	LIFT-POINT RADIUS					
		2.0 m		3.0 m		4.0 m	
1.0 m	Blade up			1560	1300	1010	860
	Blade down			2640*	1440	1770*	940
0.0 m	Blade up	1360*	1360*	1480	1220	960	810
	Blade down	1360*	1360*	3050*	1360	1990*	900
-1.0 m	Blade up	2470*	2360	1450	1200	940	790
	Blade down	2470*	2470*	3020*	1340	2010*	880

ISO 10567: Lifting capacity does not exceed 75% of tipping load or 87% of full hydraulic capacity.

* Indicates load limited by hydraulic capacity



www.casece.com
EXPERTS FOR THE REAL WORLD
SINCE 1842

CASE
CONSTRUCTION



NOTE: Standard and optional fittings can vary according to the demands and specific regulations of each country. The illustrations may include optional rather than standard fittings - consult your Case dealer. Furthermore, CNH Industrial reserves the right to modify machine specifications without incurring any obligation relating to such changes.

Conforms to directive 2006/42/EC

CASE Customer Assistance
1300 99 CASE

The call is free from a land line.
Check in advance with your Mobile Operator if you will be charged. Toll free number not available from all calling areas.

creative-farm.it 06/17